

493
E-27



Referência: 493.
Linha: Meio Squadro
Aplicação: Plafon
Descrição: Plafon Quadrado Meio Squadro 50x12x50

Material: Lâmina Natural de Madeira, MDF e Acrílico Leitoso
Peso (sem embalagem): 5,03kg/11,09lb

Tipo de Lâmpada: E-27
4x 25W (max. cada)
Fluorescente ou LED
Lâmpada não inclusa

Temperatura de Cor: Dependente da lâmpada
IRC: Dependente da lâmpada
Fluxo Luminoso: Dependente da lâmpada

Isolamento: Classe II
Tensão de Entrada (VAC): 110 ~ 277V
Frequência de Entrada (Hz): 60 Hz

Comprimento do Cabo Elétrico: Não se aplica

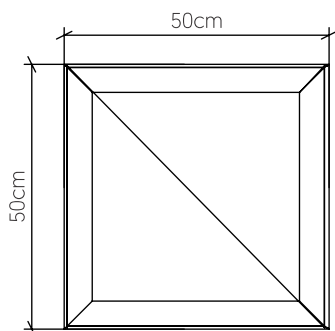
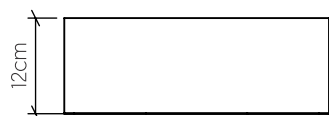

OPÇÕES DE ACABAMENTO



02
PRETO FOSCO

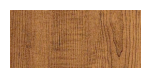

06
IMBUÍA



07
BRANCO



09
LOURO FREIJÓ



12
TECA



15
CAPPUCCINO

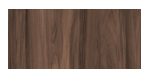

18
NOGUEIRA



25
BRANCO FURTA COR



27
OURO



30
VERDE OLIVA

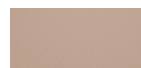

33
BRONZE



34
MAPLE

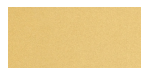

38
PALHA



39
CHUMBO



40
AZUL CETIM



43
FREIJÓ CATEDRAL