

WARNING!



Be sure electrical power is OFF before and during installation or maintenance.
The luminaire must be installed by a qualified electrician, in accordance with all applicable local codes.

Ensure that the rated luminaire voltage requirements are compatible with the available mains supply in which it will be installed.
All LEDs are included in your lamp. Never touch the LED surface with your bare hands as this may reduce the life of your LED.
Do not alter, relocate or remove any electrical component.

Line: CASCADE
Family: WALL
Description: ACCORD CASCADE SCONCE 4206

Input voltage: 120 - 240V
Input frequency: 60Hz

Material: Natural Wood Vener and MDF.

JUNCTION BOX COVER
(NOT PROVIDED)

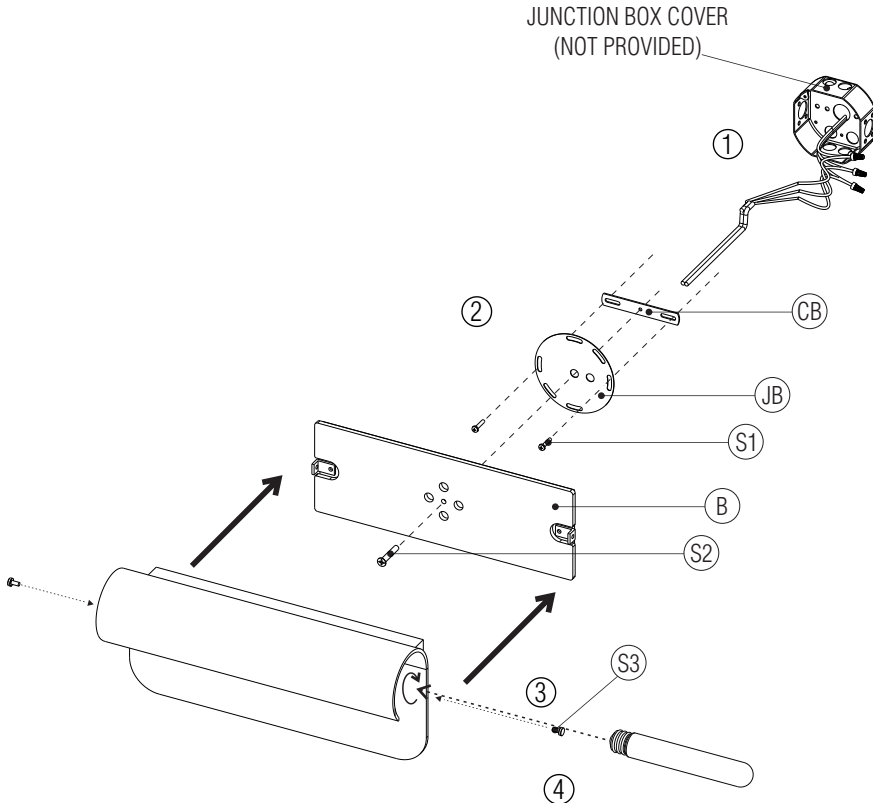

Turn off the electrical power before starting the installation, and keep it turned off until the installation is completed.

- ① Make the electrical connections in compliance with all the safety standards and local electrical codes. This product must be installed in accordance with the applicable installation code by a person familiar with the construction and operation of the product, and the hazards involved.
- ② Using the (S1) screws, fixate the crossbar (CB) and junction box cover (JB) into the junction box. Bring the support base (B) close to the wall, and using the (S2) screw, fixate the support base into the crossbar.
- ③ Next, fit the light fixture into the support base and secure it using the provided finishing screws (S3).
- ④ Install a T-10 bulb with a maximum power of 25W in the sockets provided.

Turn on the electrical power.

The luminaire is ready for use.

PROVIDED SCREWS

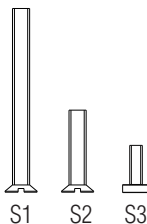

ATTENTION!

FAILURE TO COMPLY WITH THESE INSTRUCTIONS MAY CAUSE ACCIDENTS AND LOSS OF PRODUCT WARRANTY.
It's recommended to read these instructions completely and carefully before proceeding.

SAVE THESE INSTRUCTIONS FOR FUTURE REFERENCE.

ACCORD Lighting guarantees coverage against manufacturing defects including electrical components and finishes, for a period of three years, under normal use, from the date of purchase. For warranty service, please contact your local dealer for further instructions. Proof of date of purchase will be required for validation of warranty service.

The responsibility of the manufacturer regarding the product warranty is related to the correct observation of the instructions contained in this manual. The manufacturer is not responsible for any damage to the product caused by accidents, alterations of any kind, improper usage or improper installation. See the website for additional warranty details.

ACCORD Lighting reserves the right to change the dimensions and specifications contained in this manual without prior notice, in accordance with its policy of continuous product improvement. Please, contact the manufacturer if additional information is necessary. The illustrations in this manual are for guidance only and may vary in scale, dimensions and model details.